



## HYDRAULIC PUMP DRIVES FOR AGRICULTURAL TRACTOR P.T.O.

### MODEL T33

**CAST IRON CASES** Unlike our competitors, we utilise cast iron gear case construction. Cast iron expansion at the high temperatures encountered with this application is near equal to the expansion of the bearings and the outer bearing rings are retained in the case. Aluminium cases with high heat expansion often fail due to the outer bearing ring spinning and displacing particles of aluminium which destroy the bearings.

**MODEL T33 APPLICATION** These models embody over 20 years of engineering experience with PTO pump drives. They were developed for use as directly driven hydraulic pump speed increasers for 540 or 1000 RPM tractor PTO shafts. Models for 540 RPM PTO's are provided with a 1 3/8" 6T spline hollow shaft and for 1000 RPM PTO's, a 1 3/8" 21T spline hollow shaft. Shafts are splined internally for full length for through drive. Normal practice is to utilise a torque arm to restrain the drive from rotation.

Maximum power is 50 HP (37.5 kW) with the 1:3.31 ratio models at 540 RPM input and 65 HP (49 kW) in the 2.04 ratio models at 1000 RPM input. The T33 is available to accept most SAE "A", SAE "B" or SAE "C" hydraulic pumps. Pump adaptors on the T33 may be changed in the field.

T33 Ordering Information					
Hyd Pump Adaptor	Gear Ratio	Hyd Pump Shaft Type	Tractor PTO Shaft	Sleeve Part No.	T33 Part Number
SAE "A"	1:3.31	9 Spline 5/8"	1 3/8" 6 Spline	58/03/10001	<b>332/06101</b>
SAE "A"	1:3.31	11 Spline 3/4"	1 3/8" 6 Spline	58/03/10002L	<b>332/06102</b>
SAE "B"	1:3.31	13 Spline 7/8"	1 3/8" 6 Spline	58/03/01698	<b>332/06203</b>
SAE "B"	1:3.31	15 Spline 1"	1 3/8" 6 Spline	58/03/00714	<b>332/06204</b>
SAE "B"	1:3.31	14 Spline 1 1/4"	1 3/8" 6 Spline	-	<b>332/06206</b>
SAE "B"	1:2.04	13 Spline 7/8"	1 3/8" 21 Spline	58/03/01698	<b>331/21203</b>
SAE "B"	1:2.04	15 Spline 1"	1 3/8" 21 Spline	58/03/00714*	<b>331/21204</b>
SAE "C"	1:3.31	13 Spline 7/8"	1 3/8" 6 Spline	58/03/01698	<b>332/06303</b>
SAE "C"	1:3.31	14 Spline 1 1/4"	1 3/8" 6 Spline	-	<b>332/06306</b>
SAE "C"	1:2.04	14 Spline 1 1/4"	1 3/8" 21 Spline	-	<b>331/21306</b>



\* Older Models only  
 # Made to special order.  
 Other combinations available.  
**Output rotation is opposite to input rotation.**

### MODEL T33 Dimensions

Weight Unpacked - 24kg

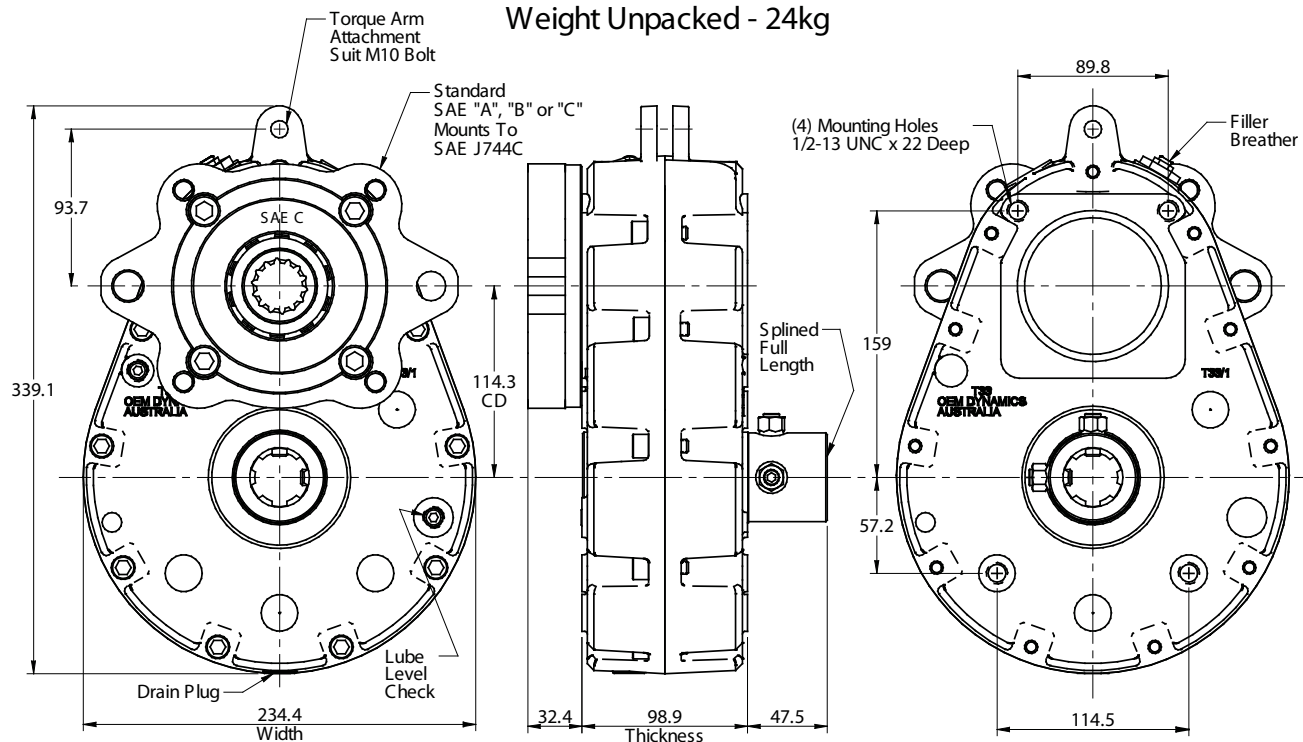

PUMP DRIVES  
DYNAGEAR T33



## HYDRAULIC PUMP DRIVES FOR AGRICULTURAL IMPLEMENT MOUNTING

### MODEL T33I

**PARTS AVAILABILITY** The drives have been designed in Australia and are manufactured at our facility in Ballina N.S.W. Customers can obtain parts and service without delay. Technical assistance is available from the people who designed the product.

**MODEL T33I APPLICATION** This model was developed for use as an implement mounted hydraulic pump speed increaser for 1000 or 540 rpm tractor PTOs where thrust loads from PTO shafts are encountered. Tapped mounting holes are provided.

Maximum power is 50 HP (37.5 kW) with the 1:3.31 ratio models at 540 RPM input and 65 HP (49 kW) with the 1:2.04 ratio models at 1000 rpm input. The T33I male shaft input model is available to accept most SAE "A", SAE "B" or SAE "C" hydraulic pumps. Pump adaptors on the T33I may be changed in the field. The T33I male shaft input & output model is supplied with a Ø1 1/2" x 3/8" keyed output shaft.

T33I Ordering Information					
Hyd Pump Adaptor	Gear Ratio	Hyd Pump Shaft Type	T33I Shaft	Sleeve Part No.	T33I Part Number
SAE "A"	1:3.31	9 Spline 5/8"	1 3/8" 6 Spline	58/03/10001	<b>332I/06101</b>
SAE "A"	1:3.31	11 Spline 3/4"	1 3/8" 6 Spline	58/03/10002L	<b>332I/06102</b>
SAE "B"	1:3.31	13 Spline 7/8"	1 3/8" 6 Spline	58/03/01698	<b>332I/06203</b>
# SAE "B"	1:3.31	15 Spline 1"	1 3/8" 6 Spline	58/03/00714	<b>332I/06204</b>
SAE "C"	1:3.31	14 Spline 1 1/4"	1 3/8" 6 Spline	-	<b>332I/06306</b>
SAE "B"	1:2.04	13 Spline 7/8"	1 3/8" 21 Spline	58/03/01698	<b>331I/21203</b>
# SAE "B"	1:2.04	15 Spline 1"	1 3/8" 21 Spline	58/03/00714*	<b>331I/21204</b>
SAE "C"	1:2.04	14 Spline 1 1/4"	1 3/8" 21 Spline	-	<b>331I/21306</b>



T33I Ordering Information - Male shaft input & output					
	1:2.04	1 1/2" x 3/8" key	1 3/8" 21 Spline	-	<b>331I/21M60</b>
	1:3.31	1 1/2" x 3/8" key	1 3/8" 6 Spline	-	<b>332I/06M60</b>

# Made to special order.  
Other combinations available.  
**Output rotation is opposite to input rotation.**

### MODEL T33I MALE SHAFT INPUT MALE INPUT & OUTPUT DIMENSIONS

Optional male output shaft arrangement available on T33 & T33i models.

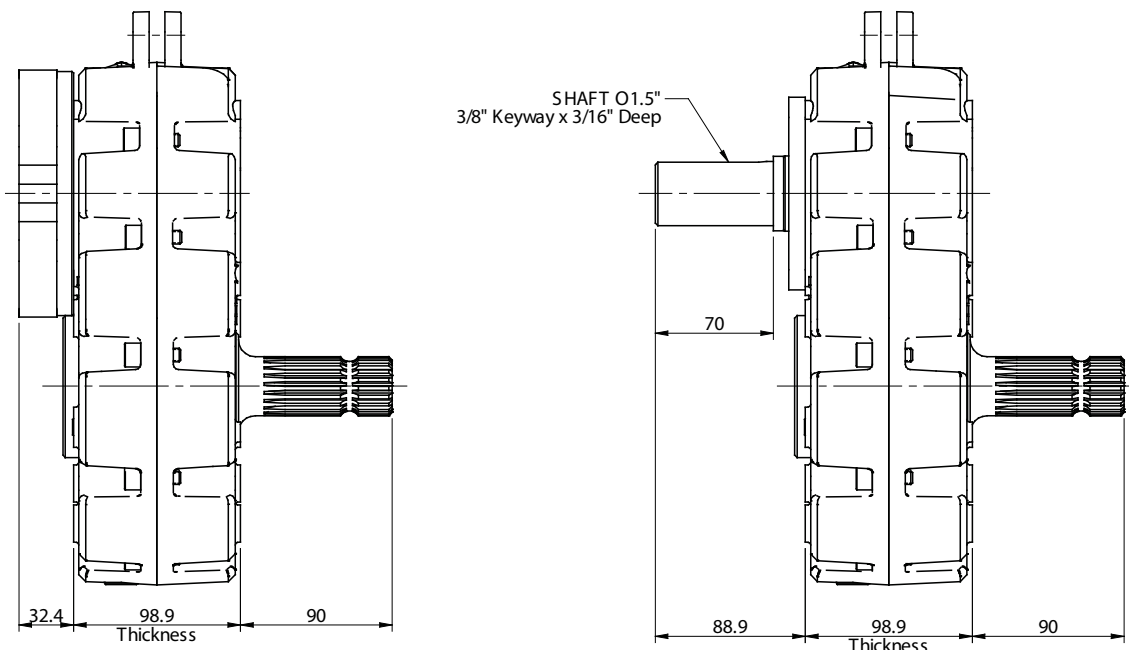

PUMP DRIVES  
DYNAGEAR T33